

ACCUPRODUCTS

OUR 37TH YEAR OF MANUFACTURING
PRECISION TOOLS FOR PRECISION MOWING!

INTERNATIONAL

Golf Course Maintenance & Mower Gaging Tools

January, 2019

Home of the ACCU-GAGE®

A precision tool for precision mowing.



page 2

Shown with Hands-Free Attachment

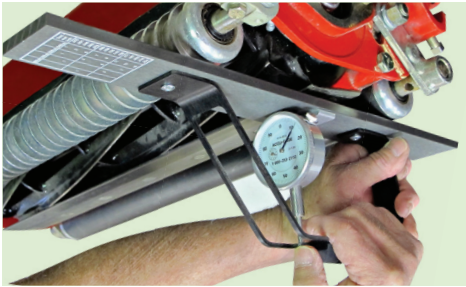

GRIP-GUARD™

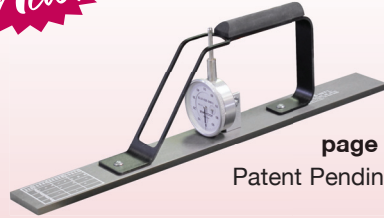

page 4

Patent Pending

PRISM-GAGE™



page 11

BENCH-PLATE™

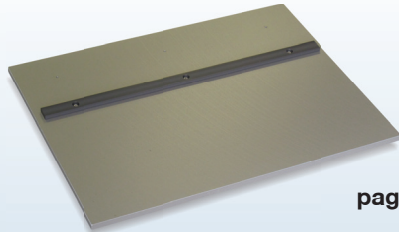

page 8

Check Out Our
Web Specials

Order Direct by Phone: (800) 253-2112 or (734) 429-9571

Fax: (734) 429-3985

www.accuproducts.com info@accuproducts.com

www.ACCUPRODUCTS.com

©2019 Accuproducts International, Inc.

ACCU-GAGE®a Precision Tool for Precision Mowing

The ACCU-GAGE is a precision measuring instrument for making highly accurate height-of-cut adjustments on greens, tees or fairway mowers.

STAINLESS STEEL INDICATOR HEAD DESIGNED TO MEASURE AT CUTTING EDGE OF BEDKNIFE

CUSTOM EXTRUDED ALUMINUM .330 THICK AND HARDENED SURFACE INSURES RIGIDITY AND LONG WEAR

FOUR SIZES AVAILABLE
13" 15" 18" 24"

HIGH QUALITY SHOCK RESISTANT GAGE
ENGLISH STYLE - .001 inch
METRIC STYLE - .01 mm
DIGITAL STYLE - English or Metric

Shown with Hands-Free Attachment

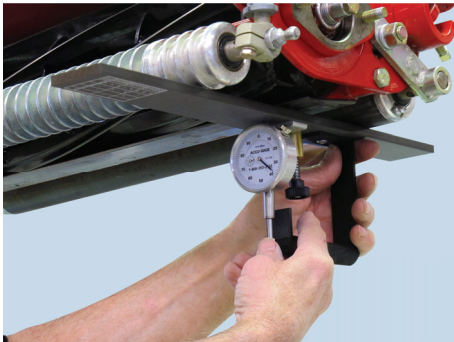

FEATURES OF THE ACCU-GAGE

- Adjustments can be made with the gage on the mower. Simply read the gage while turning the adjusting knob.
- Measurements are made at the front edge of the bedknife regardless of bedknife wear.
- Front and rear roller defects can be measured as well as bedknife defects.
- Fits all makes of Greensmowers, both riders & walkers.

HOW IT WORKS

Accu-gage is simple to use. Shown above with Hands Free and Gage Grip. See detailed instructions on p.29

OVERVIEW

Cat. #	
001-13	Accu-Gage (13" bar)
001-15	Accu-Gage (15" bar)
001-18	Accu-Gage (18" bar)
001-24	Accu-Gage (24" bar)
	Digital Version
HF-1	Hands Free Attachment
001-GG	Gage-Guard
GR-1	Gage-Grip

GO DIGITAL!

Our New Digital Gage is easy to read, measures up to 1" in both English (.001 inch) or Metric (.01 mm).



EASY TO CALIBRATE!

Just push the ZERO button



HANDS-FREE™ ATTACHMENT

Allows user to magnetically hold the Accu-gage to the mower. After gage is in place simply "push-up" the attachment.

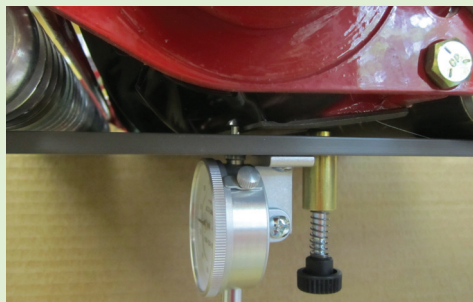

Patent # 7,392,645 B1



Use the HANDS FREE on bench settings for more consistent readings.

Cat. #HF-1



GAGE-GUARD™ ATTACHMENT

PROTECT YOUR ACCU-GAGE WITH THE GAGE-GUARD

- An added level of protection against most drops and mishandling.
- Stainless Steel construction for strength and durability.
- Patent Pending

Cat. #001-GG



REPAIR OR SERVICE? See page 30 for details

Protect your ACCU-GAGE or GROOMER-GAGE in our aluminum carrying case with die cut foam for a perfect fit.

Cat. #001AC



GAGE-GRIP™

Get a grip on your ACCU-GAGE® or GROOMER-GAGE® and securely hold and handle them while making adjustments.

New!

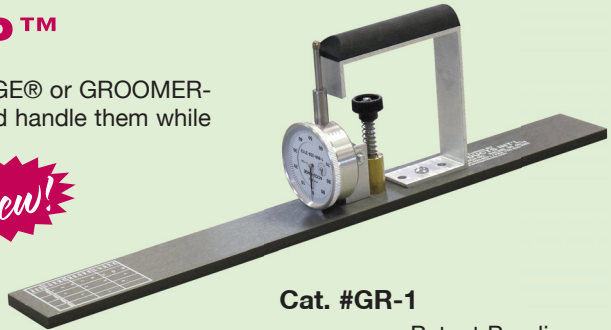

Cat. #GR-1

Patent Pending

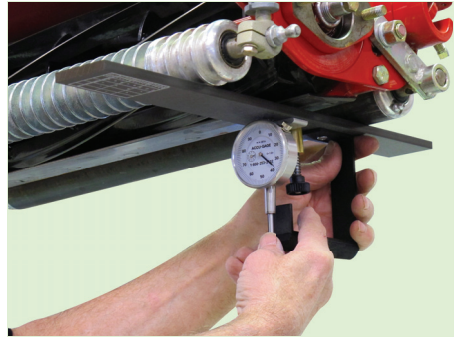
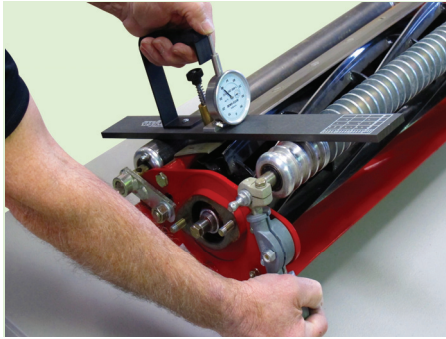

New!



GRIP-GUARD™

Cat. #GR-2

Patent Pending

Easy to hold onto when using a lift, as seen below.

The new GRIP-GUARD adds versatility and protection to any ACCU-GAGE® or GROOMER-GAGE®. The unique design also increases bar rigidity. Made from aluminum and "no-slip" grip.

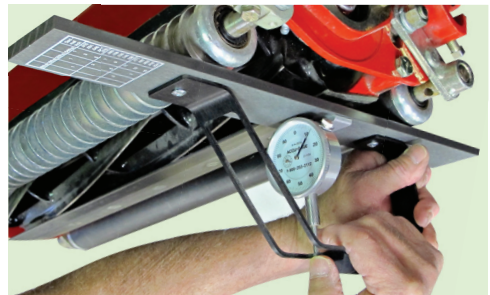

GROOM WITH PRECISION WITH THE GROOMER-GAGE®

The Groomer-Gage is a precision measuring instrument for accurately setting the desired grooming depth of groomer or verticutting units.

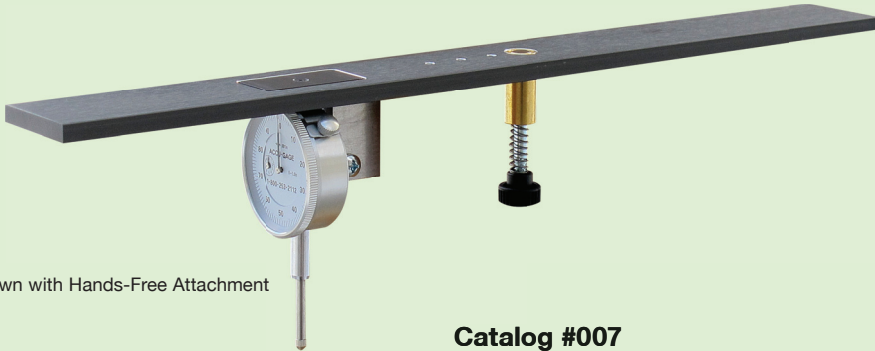

Shown with Hands-Free Attachment

Catalog #007

Digital Version #007D

Aluminum Case



Hands-Free™

can be installed on Groomer-Gage **Cat. #HF-1**

HOW IT WORKS

Easy to use, just set the bar on the front and rear rollers and, with the grooming blades rotated perpendicular to the bar, push the indicating rod up until the indicating block touches the blades. Read Gage for measurement.

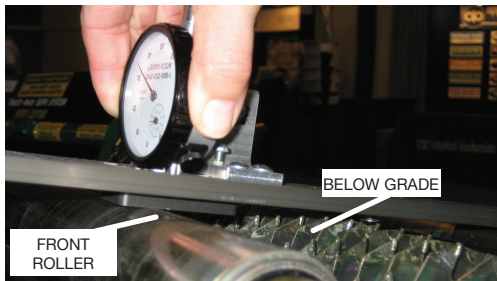
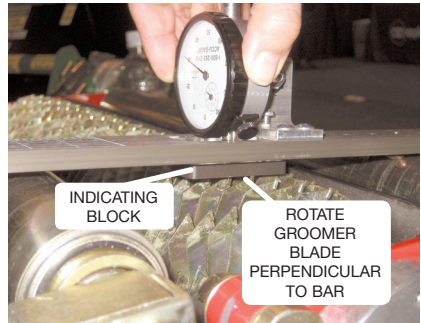

To set below grade, hold the indicating block against the front roller and the bar against the grooming blades.

ACCU-GAGE® II ... a Precision Tool for Precision Mowing

For ease in checking or setting mowers in the field or while units are still attached to mowers.

EASY TO USE. PLACE UNDER MOWER
WITH INDICATOR HEAD ON
BEDKNIFE AND
READ GAGE.

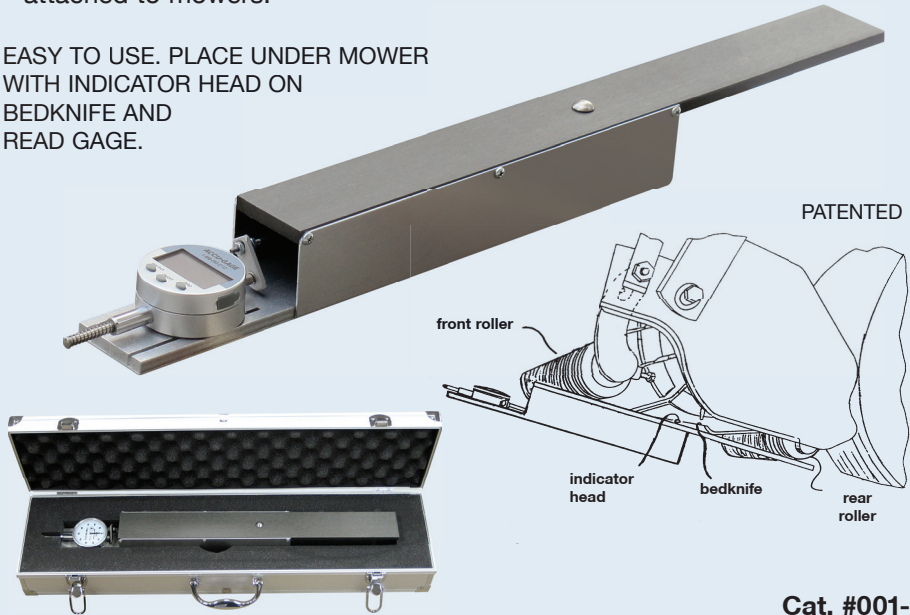

ACCU-GAGE II
SUPPLIED IN ALUMINUM CASE.

Cat. #001-II
Available in Digital Only

SIZER-GAGE™ ... a Precision Tool for Precision Mowing

Developed for use on mowers with no front rollers or when a shroud covers the top of the mower or otherwise necessitates taking the measurement from the front as shown here.



Practical range is from 1/2" – 3-1/2".

Catalog #005

ROLLER-CHECK™

Rear Roller Parallel Checking Tool



Now with
Dura-Coat
Finish

The Roller-Check is an easy to use tool for checking the parallelness of rear rollers on greensmowers or other mowers where the rear or front roller needs to be made parallel with the reel.

The Roller-Check can be used on a mower while attached to the tractor unit, on a lift, or while on a bench as shown in the photos.

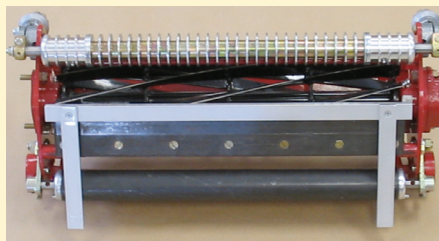

Simply set the Roller-Check on the reel with the edge of the tool resting against the bedknife and examine the perpendicular parallels. If both are touching the roller, the roller is parallel. If one side is not touching, as shown, that side must be moved towards the parallel until it touches.

- Catalog #RC-II** 22" model for greens mowers
- Catalog #RC-III** 30" model for fairway mowers
- Catalog #RC-IV** 27" model for fairway mowers
- Catalog #RC-V** Purchase all 3 sizes
- Catalog #HF-I** Hands Free Attachment (22" model only)

ROLLER-CHECK™

with Hands Free Attachment
Plus Attitude Adjustment



With the new Hands Free Attachment the Roller-Check can be used without holding in place, making adjustments on a lift easy. Proper attitude can be set using a pre-adjusted measuring screw, thus keeping all mowers at the same attitude.

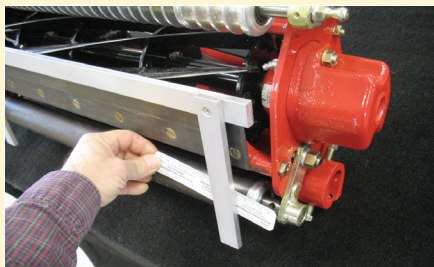

Order all three in our NEW kit Cat. #RC-V

Manufactured by ACCUProducts Int'l - Call 800 253-2112 or 734 429-9571
www.accuproducts.com email us at info@accuproducts.com

BENCH-PLATE®

The BENCH-PLATE is a useful utility surface plate, with an attached parallel bar for use in setting mower rear rollers parallel with the reel. Manufactured from precision ground aluminum with a Dura-Coat hardend finish. Parallels can be stacked to increase thickness.

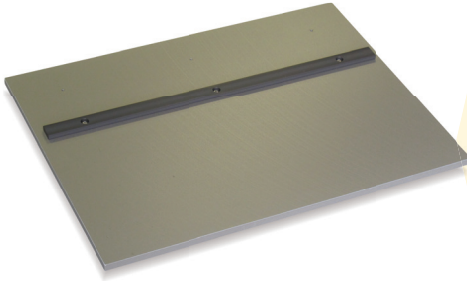

006-A

20" x 36" Bench Plate

The model 006-A Bench-Plate is ideal for mowers of all sizes. This model has an attached parallel measuring 3/8" thick. Flatness tolerance .004".

Catalog #006-A

Extra Parallel #006-AEP

006-B

18" x 24" Bench Plate

The model 006-B Bench-Plate is ideal for mowers up to 26". This model has an attached parallel bar measuring 5/16" thick. Flatness tolerance .003".

Catalog #006-B

Extra Parallel #006-BEP

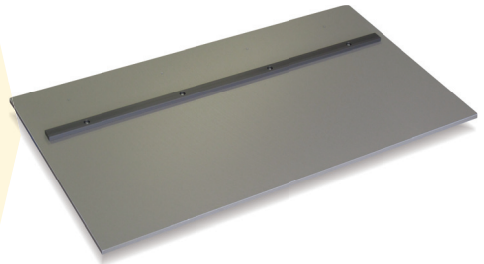

How it works...

- 1) Set reel on top of parallel bar and set bedknife against the edge of the parallel.
- 2) Hold mower in place.

- 3) Using a feeler gauge, check the rear roller at each end. If feeler gauge slips at one end, adjust per owners manual.



Set Reel on top of Parallel Bar

1

Set Bedknife Against the edge of the Parallel

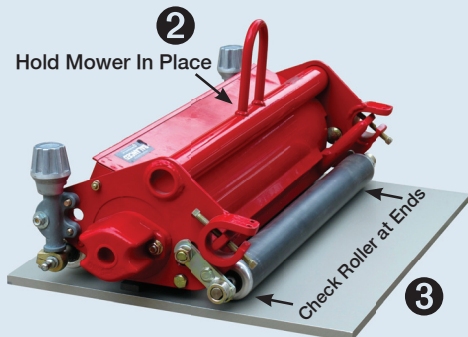

Hold Mower In Place

2

Check Roller at Ends

3

GRANITE BENCH-PLATE®

The Granite BENCH-PLATE® has a very high accuracy tolerance, which is great for mowers under 22". We recommend granite where the plate will not be moved. It is heavy and will require a heavy duty bench for placement.

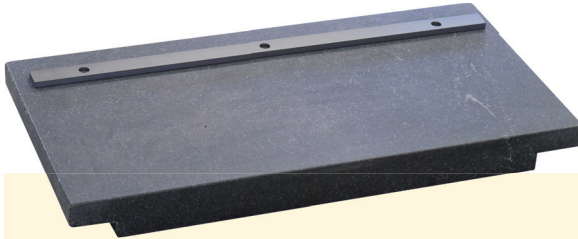

Specifications

- 12" x 24"
- Grade B
- Flatness Tolerance .0005
- Comes with parallel
- Net Weight Approx 75lbs

Catalog #006-G



ANGLE-CHECK™

Check your bedknife attitude with our new ANGLE-CHECK™. Digital and magnetic, the ANGLE-CHECK™ is the easy way to check your bedknife attitude.

Catalog #001-AG



STEP 1

Set the ANGLE-CHECK on the ACCU-GAGE® bar & press the "zero" button.

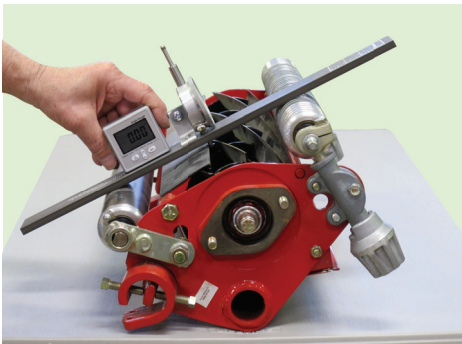

STEP 2

Set the ANGLE-CHECK™ on the bed-knife and read angle in degrees.

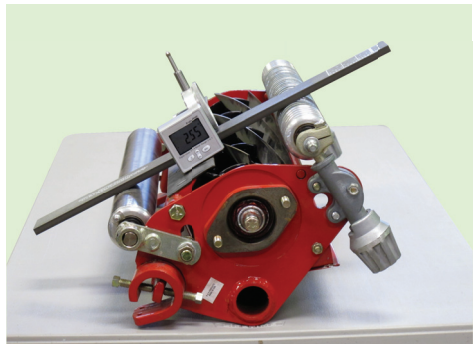

Refer to your owners manual for proper angle degree. Charts available on our website www.accuproducts.com

12" REEL CALIPERS

Now you can easily determine if your reels are "cone" shaped. These 12" dial calipers have extension jaws that enable you to measure the large diameters of reels. Simply turn the reel inside the jaws until you have contact. Measure each end to determine extent of cone shape, if any.

- Measure inside, outside, and depth
- Jaws extend 6 1/2"
- Measures in .001 inch
- Wood case included for easy storage

Cat. #101RC

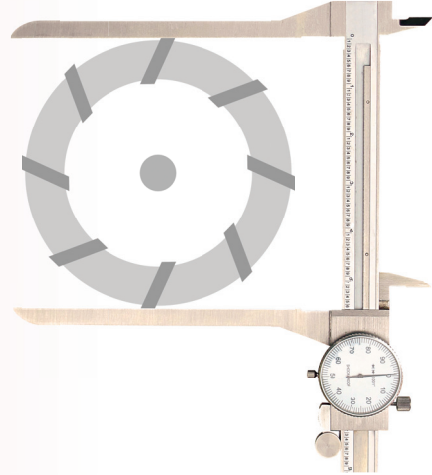

GREEN SPEED METER

Measure green speed using the standardized ball roll measurement method. This enables the superintendent to make statistically accurate measurements of a putting surface speed. Comes with complete instructions.

- Extruded Aluminum
- Anodized
- Measuring tape attached to back
- Calibrated to provide accurate readings

The new short version is designed to be used on green surfaces with small flat areas where accurate ball rolls are difficult with the regular green speed meter. Simply double the measurement to get the same results as the standard model.

Cat. #GS101

Short Model

Cat. #GS101S

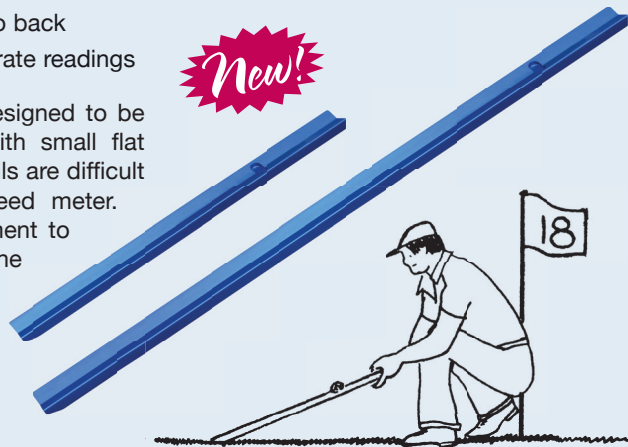

PRISM-GAGE™

The PRISM-GAGE is a right angle prism with precision measurement lines inscribed on one face of the prism. When viewing through the PRISM-GAGE, these graduated lines are superimposed on the turf so the viewer may measure the actual height of the turf-grass and thus be able to compare it with mower bench settings. The observer may also inspect the "quality" of cut by comparing the turf over the viewing plane of the prism.



As light enters the prism the viewer compares the cut turf against the measurement lines.

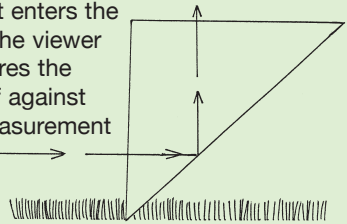

From the viewer's perspective looking down.



Lines are inscribed at .100, .200, .300, .400, .500, .750, 1.0, and 1.5 inch. The lines appear superimposed on the turf enabling the observer to determine actual height of cut. By slightly tilting the prism, a larger overview of the turf may be viewed in order to observe the "quality" of cut.

Cat. #PG-01



FREE Wood Protection Case included!

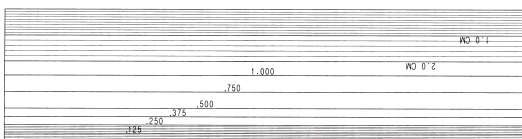

OPTIONAL FILM TRANSPARENCY

The film transparency is an overlay with graduation lines at .025 (inch) intervals which allow the user to more closely measure the height of cut.

Cat. #FT-01



KELWAY SOIL TESTER

Direct reading soil tester for PH and moisture. Tests soil in 3 minutes.

- No batteries or chemicals needed.
- Reliable, accurate, portable.
- Only 6 1/2" long – weighs 8 oz.
- Comes complete with carrying case.



Cat. #HB-2

SQUARE-CUT™

TURF PATCHING TOOL

- Soft handle grips for ease of operation
- Tubular design allows for stacking of plugs
- New stainless steel construction
- Adjustable depth stops assure uniform plug.
- Thickness range is from 2" to 3".
- Cuts a 5.5" sq. plug
- New tapered design for easier plug removal



Pat.# 5,826,668

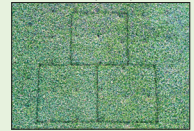

SQUARE-CUT

Handles all your patching needs

Cat. #010SQ

SOIL INSPECTION TOOLS

TUBULAR SOIL SAMPLERS

The large sampler removes a plug 15" x 3/4" and the small sampler removes a 7" x 1/2" plug. Made from stainless steel.



Large Sampler Cat. #012T

Small Sampler Cat. #013T

HEAVY DUTY STEP SAMPLER



The 36" Heavy Duty Step Sampler removes a plug 12" x 3/4" and is made from stainless steel. Offers extra penetrating power for hard soils. Easily use the step to press into soil.



Heavy Duty Step Sampler Cat. #014T

TRU-DEPTH™ SAND PROBE



New!

You have a big investment in your sand bunkers; help keep them as they were designed and constructed with the Tru-depth Sand Probe. The Tru-Depth Sand Probe provides quick way to check the depth of bunkers. Insert the probe into the sand and quickly read the true compacted sand depth.

"Specially designed by the folks at Better Billy Bunker, the fastest draining and best bunker construction method in golf."
- Better Billy Bunker

- Easy to use!
- Measuring depth 0 - 7"
- Easily readable gauge
- Aluminum & Stainless Steel

Cat. #TRU-07

TURF AERATOR



Our Turf Aerator comes with four (4) replaceable and adjustable tines, and a removable aluminum tray for collecting plugs if desired.

Cat. #AER-01

SAMPLE PRO™

The Sample Pro™ makes it easy to inspect soil layering, root development, etc. Removes a cross section of soil 6" deep, 2 1/2" wide and 1/2" thick. Cutting head made from stainless steel.

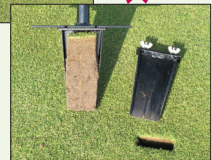

Cat. #011T

SandComb™

NOW – EASILY REMOVE STONES AND DEBRIS FROM YOUR SAND BUNKERS!!!

THE CATCH

is in the light weight cast aluminum construction and the sturdy, galvanized steel wire mesh.

The mesh sifts and separates debris. Two different mesh sizes are quickly interchangeable to meet your needs.

Pat. #
4,828,690

2 SCREEN SIZES AVAILABLE

“1/4” -For Pea Stones

“1/2” - Regular Use

SPECIFICATIONS

Width 16” or 22”

Height 4”

Mesh 1/2” or 1/4”

Handle Length 60”



THE EDGE

The secret is the patented double-edge double-angle design that easily lifts, separates debris from the sand’s surface.

Great for bunkers, beaches, and volley ball courts.



Available in two sizes - 16” and 22”!

OVERVIEW

Cat.

SC100 (16” model)	Sand-Comb
SC101 (22” model)	Sand-Comb
SC-1	Extra Screen (for 16”)
SC-2	Extra Screen (for 22”)



LANDSCAPE RAKES & TOOLS

TURF TOPDRESSING LEVELER

Our heavy duty topdressing leveler is great for small jobs such as divot repair on tees or leveling repaired turf on greens, tees, or fairways. The leveler can be flipped over for working in sand or topdressing.



New!

Features:

- Heavy duty construction
- 60" Aluminum handle
- Rubber grip
- 15" x 28" Head

Cat. # TTL-1

SLEIGH TINE

FOR SAND RAKING MACHINES

Improve sand bunker raking with the SLEIGH TINE. The Sleigh Tine replaces straight tines found on most sand raking machines. The tine's 45 degree bend helps it to avoid catching pulling up barrier fabrics, stones and any subsurface material. Tine is 3/8" dia.

Avoid digging up subsurface material!

Cat. # SLT-01 1.05 each
Cat. # SLT-20 bag of 20





LANDSCAPE/LEAF RAKE

This is the ideal rake for smoothing and leveling surfaces, seedbed preparation, sand bunker and beach cleanup and leaf raking. It has a 60" powder coated aluminum handle and a 36" head.

Catalog #10036



SEYMOUR



BACKFILL RAKE

This is a great tool for quickly backfilling trenches, moving soil and aggregate materials. Heavy duty replacable heads and a 60" powder coated aluminum handle and a 20" head.

Catalog #73320



KEYNOR



PLUG PUSHER

The plug pusher is used for moving and leveling sand and loose material and cleaning off flat surfaces. Use one side to push, and the other side to pull. 36" head.

Catalog #51736

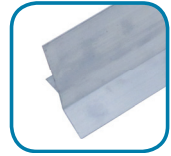

SEYMOUR



DUAL PURPOSE RAKE

This innovative and versatile tool has two teeth profiles. The short teeth are used for breaking up hard packed clay and grading, while the long teeth are for wet and general raking. 36" head.

Catalog #12536



SEYMOUR



AQUATIC WEED ERADICATOR

The AWE, is the most effective bottom cutting weed removal tool available on the market. You dont have to worry about the re-enforced blades bending under heavy loads of weeds. 36" head.

Catalog #87028



SEYMOUR



SCARIFIER LUTE RAKE

This rake has fine serrated teeth that break up hardened surface materials, while the extended grading edge smooths and levels while spreading materials. 36" head and 60" powder coated aluminum handle.

Catalog #52936

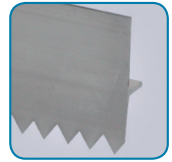

SEYMOUR

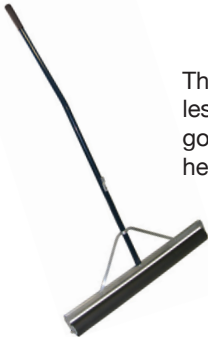

ROLLER SQUEEGEE

The heavy-duty aluminum frame construction and stainless steel axles ensure this roller stays secure. Great for golf greens, floors, tennis courts, and sports fields. 36" head.

Catalog #70736



SEYMOUR



7' DRAG BROOM

The 7' drag broom is a great finishing drag broom but can also be used as a topdressing broom on the greens and around the tee boxes. Flip the rake over and use the scarifier edge for a perfect finish.

Catalog #82384

SEYMOUR



Ratcheting PVC pipe cutter

- 2" max cut

Catalog #41436

36" Cable Saw

- 36" cable blade
- Cuts PVC, CPVC, ABS & poly pipe
- T-Handles

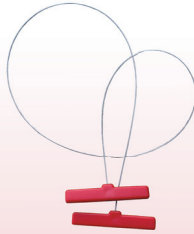

Catalog #41448

Sprinkler Valve Keys

30" Sprinkler Key
Catalog #85482

54" Sprinkler Key
Catalog #85483



18" PVC saw



- 18" Blade

Catalog #41446

PVC SPANNER NUB WRENCHES

This high strength zinc plated steel design provides the proper two-point "push/pull" leverage needed for tightening PVC compression couplings—preventing damage and distortion often caused by the use of pipe and chain wrenches. Each wrench will fit two sizes of PVC.



Catalog #

#1215

#2025

#3040

#6000

Order Complete Set
Includes (2) of each wrench
#21236



PVC Size	1.25"		1.50"		2.00"		2.50"		3.00"		4.00"		6.00"	
	Nut	Body	Nut	Body	Nut	Body	Nut	Body	Nut	Body	Nut	Body	Nut	Body
#1215	X		X			X								
#2025					X		X	X		X				
#3040									X		X	X		
#6000													X	X

HYDRO-EZZ Wetting Agent

Hydro-Ezz is easy to apply

Hook-up to your hose and drop one HYDRO-EZZ tablet into the applicator bowl and hand water as usual. No additional time or labor required.

- 30 / 4oz. HYDRO-EZZ turf wetting agent tablets
- Eliminate mixing, leaf burn and experience needed to apply chemicals
- Wets hydrophobic spots in seconds

Catalog #222RF



HYDRO-EZZ APPLICATOR

- Solid brass fittings
- Evenly Dissolves Hydro-Ezz Tablets
- ACCUJET nozzle
- 3/4" & 1" fittings

Catalog #222APS



HYDRO-EZZ Starter Package

- 30 / 4oz. HYDRO-EZZ turf wetting agent tablets
- (1) Hydro-Ezz Applicator

Catalog #222HES



ACCUJET NOZZLE

Adjustable from gentle fan to jet stream by twisting body.

- 3/4" and 1" hose connection
- Solid Metal body with NO plastic parts
- Brass, Zinc Alloy, black PVC

Catalog #AJ34



HOSE ADAPTOR

3/4" to 1", Aluminum

Catalog #20A



HOSE REDUCER

1" to 3/4", Brass

Catalog #20R



SPECIALTY IRRIGATION PRODUCTS



Cat. #008WF2

WETTING FORK™ II

The Wetting Fork...

- Wets hydrophobic spots in seconds
- Has new improved stainless steel tines that can be used to inject fertilizers, fungicides and insecticides or wetting agents
- Reduces wetting agent use
- Complete with valve and hose fittings for ¾" and 1" hose.
- Welded steel construction.
- Comes with (3) stainless steel perforated tines.



Easy to use! Simply push tines into ground and open valve!



New!



Add the base plate to keep larger areas flat when injecting water and keep water from returning to surface from previous holes. Base plate measures 4" x 14" & screws on the bottom of unit and is easily installed or replaced.

Add Base Plate cat# WF2P
Replacement Tines Cat. #008T

(U.S. Patent #5.398.445)

Hand Operated Water Pump

Recommended for small flooded areas.

An excellent general purpose pump for a variety of water transfer needs. Made of high impact PVC. Needs no priming. Has 1¾" diameter body and can be used to pump out valve boxes up to 6' deep.

CAT. #	BODY LENGTH	DISCHARGE LENGTH	VOLUME
136PF-6	36"	72"	35 oz/stroke
172PF-6	72"	72"	35 oz/stroke



12 Volt DC Submersible Pump

Recommended for irrigation repair holes.

Our smaller submersible pump is ideal for water removal in irrigation repair holes, trenches, flooded areas and a variety of uses where a small pump is needed. *Pumps up to 18GPM.*

Cat. # SP01

1" discharge hose sold seperately

Cat. #SP01DH



12 Volt Heavy Duty Pump

Recommended for irriation repair and flooded areas.

Our heavy duty submersible pump is ideal for water removal in irrigation repair holes, trenches, flooded areas and a variety of uses where a small pump is needed. *Pumps up to 35GPM.* 3/4" and 1" hose connector included.

Cat. #SP-02



12 Volt High Capacity Battery Powered Pump

Recommended for large flooded areas.

The model 12V4700 is ideal for pumping out sand bunkers and other flooded areas. Pumps up to 75 gpm. Easy to use – just attach battery clamps to any 12 volt d.c. battery.

Cat. # 12V4700

2" Collapsible hose sold seperatly

Cat. # 2CH



MEASURING & INSPECTION TOOLS

2.5 POWER POCKET MAGNIFIER



531

- Has 2.5 power ground and polished optical glass.
- Folds into case for storage.

NO. POWER
531 2.5 Leather case

PRECISION STEEL RULE

This precision 6 inch rule made from the finest stainless steel available and is hardened and tempered. Measures both inch and metric.

Frontside

- Top edge 1/2 mm, mm
- Bottom edge 1/16ths, 1/32nds, 1/64ths.

Reverse Side

- Conversion table, fraction to decimal.

NO.
1302



When you purchase any ACCU-GAGE® or GROOMER-GAGE®.

MAGNETIC BASE

- Base is constructed with a V-groove for placement on round surfaces.
- 85 Lbs. pull.
- On and off lever releases magnet.
- Attaches to milling machines, lathes, grinders, etc.
- Universal clamp for dial indicators, electronic probes, etc.
- Indicator included.



MB 001

PROTRACTOR, MAGNETIC LEVEL

- New, multi-purpose tool functions as evel, protractor, square, and pitch gage.
- Measures angles in full 360° range.
- Accurately transfers angles and measures pitch angles.
- Instantly adjustable.
- Individually carded.

845



NO.
845

PRECISION MACHINED GAUGE BLOCK

- Precision Machined Gauge Block for calibrating the ACCU-GAGE.

NO.
GB-10



TURF MICROSCOPE

The Turf Microscope is a great tool for any superintendent who needs a better view of the Health and Quality of their turf. Two components combine to create three different optical devices. A 8x20mm Monocular, 3x power stand Magnifier, and when threaded together, a precision 25x portable Microscope.



Benefits

- Easily Inspect the Quality of cut of your Turf Grass at 25x Power!
- Identify physiological conditions such as diseases and nutrient Issues.

Features & Specifications

- Built Light Weight & Portable
- Fully Coated Optics
- Rubber Eye Piece can be used with or without Glasses
- 20mm Objective Lens
- Dimentions 7" x 2" x 2"

Cat. #TM-25

BINOCULAR HEADBAND MAGNIFIER

WITH TRIPLE LENS FEATURES

- From 2.2X to 5.2X without removing headband
- Headband is attached with Velcro™-like material
- Hard-coated scratch-resistant acrylic lenses
- Continuous lens provides unobstructed field of vision
- Extremely light – only 4.2 oz. (114g)
- Detachable LED light source



Pivots allow the visor to be tilted out of the way when not in use

CATALOG #	POWER	DIOPTER	WORKING DISTANCE
OPGM232	2.2X	4.80	16.7" (170mm)
	3.3X	9.30	4.0" (100mm)
	4.1X	12.5	2.5" (65mm)
	5.2X	16.9	1.8" (45mm)

ELECTRONIC DIGITAL CALIPERS

- Outside, inside, and depth measurements are quickly obtained and read out on the high contrast LCD display.
- True inch/metric conversion without rezeroing.



Cat. #MG8206

Makita FAST-GRIND™

Our Makita FAST-GRIND is a high performance angle grinder with a adjustable attachment to facilitate front edge bedknife grinding (also called facing). This allows the user to set the angle of cut as recommended by the mower manufacturer. The adjustable pin moves the reel blade ahead of the grinding disc as shown to the right. The attachment can be removed for other uses of the grinder.



MFG-1A

STANDARD MODEL

Recommended for Aggressive Cutting

Speed of 10,000 rpm

Includes:

Adjustable angle attachment

(4) Grinding disks

(1) Extra Pin

Complete Instructions

MFG-1A

VARIABLE SPEED MODEL

Recommended for Delicate & Aggressive Cutting

Speed of 2800 — 10,500 rpm

Includes:

Adjustable angle attachment

(4) Grinding disks

(1) Extra Pin

Complete Instructions

MFG-4A



MFG-4A



Extra Grinding Disc
WH-1

Makita CORDLESS FAST-GRIND™

The Cordless Makita Fast-Grind is ideal for all types of grinding where cordless application is necessary. The customized angle attachment is used to facilitate in front edge bedknife grinding (also called facing). The attachment can be removed for other uses of the grinder.



MFG-2C

CORDLESS MODEL

Speed of 10,000 rpm

MFG-2C

Cordless Grinder Includes:

Adjustable Angle Attachment

(1) Battery

(1) Rapid battery charger

(4) Grinding discs

(1) Extra Pin

Complete Instructions



30 MINUTE RAPID CHARGER

Charger communicates with the battery's built-in chip throughout the charging process to optimize battery life by actively controlling current, voltage and temperature.

— Included with MFG-2C



Extra Battery

MFG-18V

BEDKNIFE BUDDY

The Bedknife buddy is a quick and easy way to lightly "touch up" greensmower bedknives. The unique nylon holding block moves the real out of the way while the file (replaceable) puts a light clean up edge on the front face of the bedknife.

#BB-01

#BB-01F (replacement file)

#BB-01P (pin guide)



THE TIRE PLUGGER

When Puncture prevention fails use the cure!

Tubeless tires on golf cars and rider mowers can be easily repaired with the TIRE PLUGGER. When flats happen you need to cut your downtime. Do it yourself with this 'on the spot' – 'on the wheel' repair. The gun 'drives' the plug into the hole. It then expands under pressure to plug the puncture. The mushroom head seats on the inner wall to seal the hole.



Kit Includes:

- (25) 5/16" diameter plugs in 3/4" length
- Nozzle and Probe Tool
- Reaming Tool
- Retractable Razer Knife
- Vinyl Zipper Pouch
- Full Instructions

**Tire Plugger Kit
Cat. #1075**

**Extra Plugs: (50 plugs)
Cat# 1085-3075**



EZ-AIR TIRE GAGE

The EZ-Air Tire Gage easily clips onto any tire valve stem and gives instant, accurate pressure readings up to 100 PSI. The self-locking brass air chuck makes a positive seal and prevents air loss during the inflation or deflation process.



***Tire pressure management
doesn't get any easier!***

Cat. #EZ-02

HOW TO USE:

If the tire pressure is too high, release by pressing the bleed button on the top of the gauge.

If the tire pressure is too low, attach a compressor to the brass valve stem on the right side of the gauge. The gauge instantly becomes an in-line gauge. The 2" dial displays real-time pressure as the tire inflates.

FOLEY BACK LAPPER

Ideal for quick touch up of all your reel mowers between major sharpening, the Model 365 Back Lapper from Foley United quickly sharpens and hones your reels and bedknives giving them a fine cutting edge. It can sharpen gang mowers while still connected to the frame and the tractor.

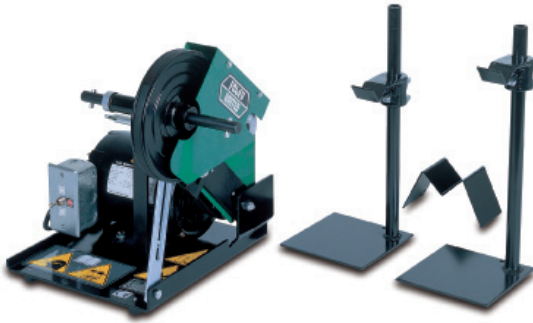

Model 365 Back Lapper

Standard features:

115V ½ HP Reversing Motor
Lapping speed 116/140 rpm
Adjustable Roller Bracket Mower
Stands

Cat. #365

FOLEY HOLE CUTTER SHARPENER

This easy-to-use sharpener quickly puts a razor sharp edge on your hole cutters in a matter of seconds. Works well on 3-scallop, 4-scallop, or plain edge cutters by simply changing disk sizes. With a reversible grinding disk, it can sharpen up to 400 edges before the disk needs to be replaced.



*That sharp edge
you've been
looking for!*

Model 386

Hole Cutter Sharpener

Standard features:

115V ½ HP Motor
Operates at 2850/3450 rpms.

Comes with (1) Grinding Disk
of your choice.

Cat. #386

Grinding Disks

3½" dia. grinding disk for
4 - scallop cup cutters.

Cat. #386-1

4" dia. grinding disk for
3 - scallop cup cutters.

Cat. #386-2

LIMITED TIME OFFER!



CUSTOM WOOD CASE

While they last, these quality custom wood cases are made from solid ash and come with custom die cut foam to fit our ACCU-GAGE or GROOMER-GAGE products. Hand rubbed finish oil finish for lasting durability.

Cat. #001-WC

Purchase with ACCU-GAGE or GROOMER-GAGE

Custom wood case also available for the PRISM-GAGE™.

Cat. #001-PWC



FREE with any PRISM-GAGE™ purchase!

PRECISION STEEL RULE

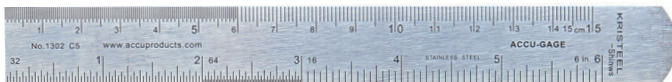

When you purchase any ACCU-GAGE® or GROOMER-GAGE®.

Learn more on pg 22

HOW TO USE THE ACCU-GAGE and THE RULES AND TOOLS FOR PRECISION MOWING

Striving for accuracy beyond practical limits can be both inefficient and frustrating. It is always best to establish a tolerance of accuracy that can produce the desired result without being too difficult to achieve or maintain. The following are some suggestions based upon our own experience and the experience reported by other mechanics and superintendents.

Mower	Desired Cutting Height	Suggested Tolerance
Greensmower	.090-.250	4% of setting. For example: Setting = .125 tolerance = +- .005
Tee or Fairway	.300-.500	7%
Fairways	.500-1.00	10%
Roughs	1.50 and up	15%

Hold the instrument in place and read gage

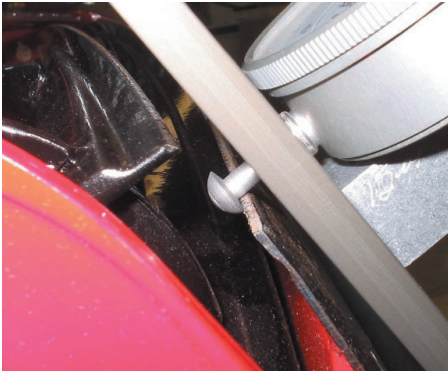

HOW TO READ THE ACCU-GAGE

Graduations are in .001". Each revolution on the large dial represents .100" and is counted on the small dial. The reading shown is .188".



For additional instructions and product information please visit us online. Online you will find downloadable PDF instructions for many of our products including the ACCU-GAGE.

REPAIRS AND SERVICE-INSTRUCTIONS FOR RETURNING YOUR ACCU-GAGE PRODUCTS

If your ACCU-GAGE should need service, please send it to the address on the order page (p. 31). The address is also located on the bar of the tool. Please send us your name, phone number, and return shipping address, along with your billing address and any special instructions. Our service department will promptly repair and return your item.

WARRANTY INFORMATION

All ACCU-GAGE repairs are warranted for 30 days against defects in parts and workmanship.

All new products that we manufacture have a limited warranty for one year from defects in workmanship and materials. Products we sell but do not manufacture are warranted for the same period of the manufacturer warranty. Call if you have any questions. Warranty does not include calibration or maintenance or damage due to misuse or breakage.

All products come with a full 10-day unconditional satisfaction guarantee. If you are not completely satisfied with any of our products, just send them back and we will refund or credit your account.

**ACCUPRODUCTS
INTERNATIONAL**
7836 Bethel Church Rd.
Saline, Michigan 48176

TOOLS FOR GOLF COURSE SUPT. & MECHANICS



WWW.ACCUPRODUCTS.COM
Fast and easy checkout, track your order, and more!

Visa, MasterCard, Discover, Paypal or purchase order

New! **ANGLE-CHECK™**

Check your bedknife attitude with our new ANGLE-CHECK™. Easy to use tool for checking attitude of bedknives.

See page 9 for details

